

AUTOMATIC PACKAGING MACHINERY MANUFACTURER

自动化包装机械设备



27+ 年行业生产经验 5000 平方标准生产厂房 集 研发、生产、销售、售后服务 于一体

COMPANY PROFILE

公司简介

佛山市峰拓机械科技有限公司作为一家自动化设备的高新技术企业，集研发、制造、销售及售后服务于一体，一直致力于为客户提供专业生产包装机及相关配套设备，非标定制包装生产线。产品广泛运用于食品、五金、玩具、化工、医药等多个行业。

公司自成立以来，一直积极引进和培养专业人才，注重 创新和开发，多次引领行业标准。拥有一系列技术人员、工程师、和销售售后服务人员，形成一支高素质年轻化极富团队创新精神的队伍。同时还拥有一套完善的服务体系（售前的方案咨询、售中的产品应用和售后的技术支持）使产品深受广大客户信赖，获得业界的认可，产品还畅销中国内地、中东、东南亚及欧美等多个国家，与朋友广泛合作，共享繁荣，也成为我们最真诚的追求。

“传承卓越，共创未来”我们将秉承坚持勇于拼搏，务实创新，不断超越，继续凭借过硬的产品和服务，期待与您的精诚合作，共同发展，愿我们能携手并进、开拓未来！

As a high-tech enterprise of automation equipment, Foshan Frontech Machinery Technology Co., Ltd. integrates R&D, manufacturing, sales and after-sales service. It has been committed to providing customers with professional production of packaging machines and related supporting equipment, as well as non-standard customized packaging production lines. Products are widely used in food, hardware, toys, chemicals, medicine and other industries.

Since its establishment, the company has been actively introducing and training professionals, focusing on innovation and development, and leading the industry standard many times. It has a series of technicians, engineers, and sales and after-sales service personnel, forming a high-quality, young and innovative team. At the same time, it also has a complete service system (pre-sales solution consultation, on-sale product application and after-sale technical support), which makes the products deeply trusted by customers and recognized by the industry. The products are also sold well in Mainland China, the Middle East, Southeast Asia and It has become our most sincere pursuit to cooperate extensively with friends and share prosperity in many countries such as Europe and the United States.

"Inheriting excellence and creating the future together" We will uphold the courage to work hard, be pragmatic and innovate, and continue to surpass, continue to rely on excellent products and services, look forward to sincere cooperation with you and common development, hope that we can go hand in hand and open up the future!



WALK INTO FRONTECH

走进峰拓



总经理GM



我们的产品畅销中国、中东、东南亚及欧美等多个国家。



销售网络



CUSTOMER CASE

客户案例



全自动包装生产线方案
FULLY AUTOMATIC PACKAGING PRODUCTION LINE SCHEME



颗粒混合物料生产线
Pellet mixture production line

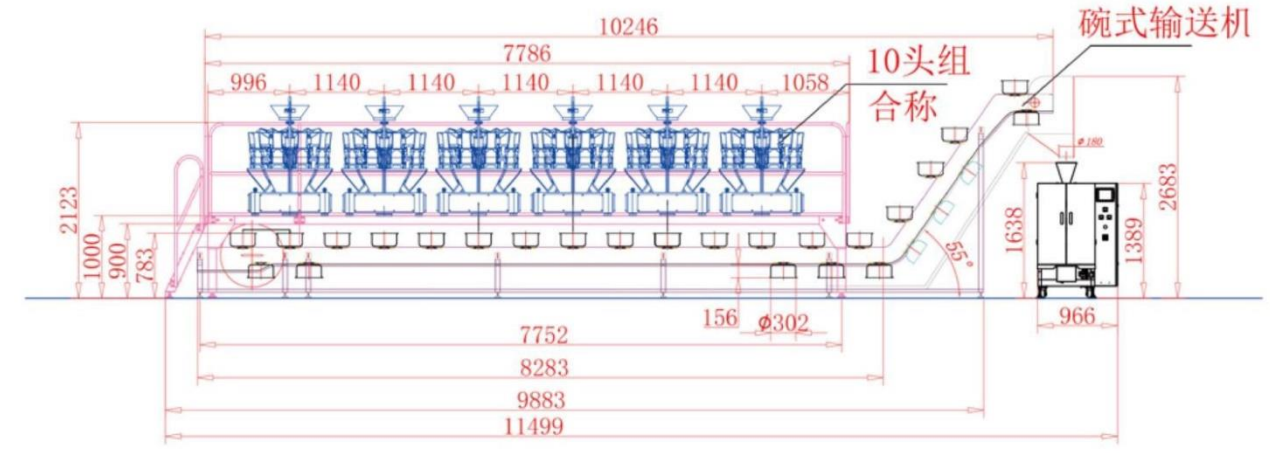

粉末混合物料生产线
Powder Mixed Material Production Line

FT-VP420A

电脑组合秤包装系列

COMPUTER COMBINATION WEIGHER PACKAGING SERIES

- ▶ FT-VP520A
- ▶ FT-VP730A
- ▶ FT-VP1200A

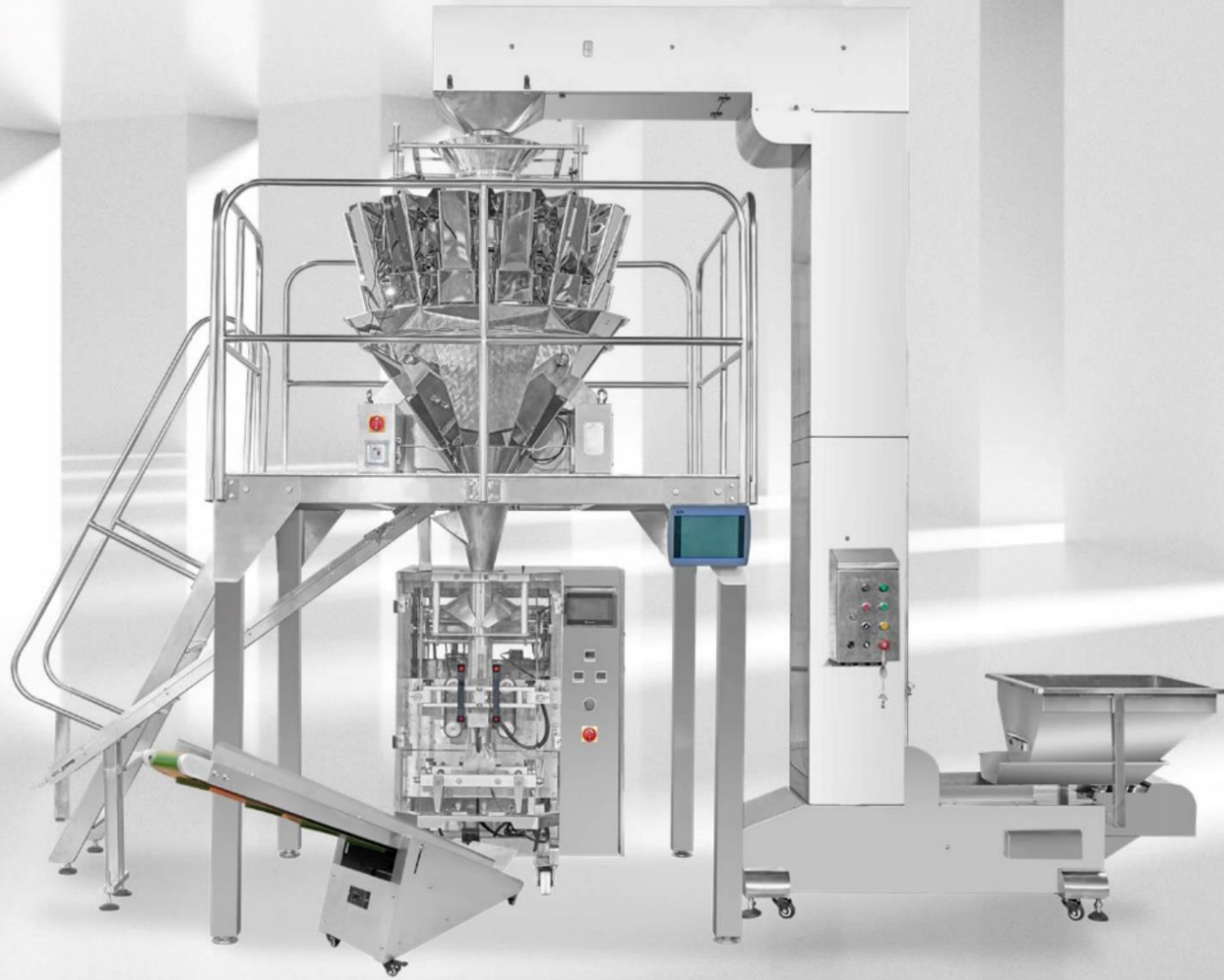

适用包装范围 Applicable packaging range



五谷杂粮



糖果食品



蔬菜食品



五谷面条

样袋展示 Sample bag display



本套机组 This set of unit



本设备技术优势 Technical advantages

- 01 适合所有要求计量精度高及易碎的散状物体的包装。如：膨化食品、锅巴、果冻、糖果、开心果、苹果片、水饺、汤圆、小五金件、药材等。
 - 02 自动完成送料→称量→充填→制袋→日期批号打印→充氮(排气)计数→成品输出全过程。
 - 03 进口 PLC、伺服电机控制，精度高、速度快，触摸屏操作，人机界面，易操作，易维护。
 - 04 输送机设计简洁，稳定提升，不碎料，干净卫生，噪声小。
 - 05 智能操作，同套设备可适用于不同重量及不同产品，节省经济成本。
 - 06 完善的报警提示功能，任何欠料，缺料及功能故障都及时报警提示或报警停机。
- 01 It is suitable for the packaging of all loose objects that require high measurement accuracy and fragile. Such as: puffed food, rice crackers, jelly, candies, pistachios, apple slices, dumplings, glutinous rice balls, hardware, medicinal materials, etc.
 - 02 Automatically complete the whole process of feeding → weighing → filling → bag making → date and batch number printing → nitrogen filling (exhaust) counting → finished product output.
 - 03 Imported PLC, servo motor control, high precision, fast speed, touch screen operation, man-machine interface, easy to operate and easy to maintain.
 - 04 Conveyor design is simple, stable promotion, no shattering. Clean and sanitary, with low noise.
 - 05 Intelligent operation, the same set of equipment can be applied to different weights and different products, saving economic costs.
 - 06 Complete alarm function, any shortage of material, material shortage and functional failure will promptly alarm or stop.

FT-VP420D

螺杆计量包装系列

SCREW METERING PACKAGING SERIES

- ▶ FT-VP520D
- ▶ FT-VP730D
- ▶ FT-VP1200D



样袋展示 Sample bag display



奶粉

茶粉



本套机组 This set of unit

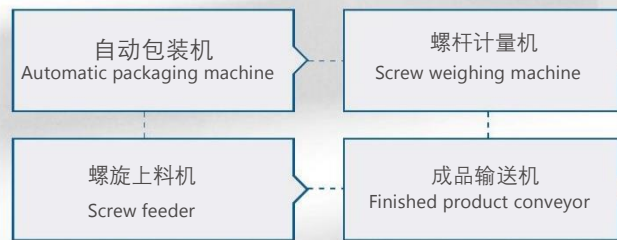

本设备技术优势 Technical advantages

- 01 适合于粉剂类的自动包装，如奶粉、面粉、茶粉、咖啡粉、甜蜜素、面膜粉、香料等。
- 02 自动完成送料→称量→充填→制袋→日期批号打印→充氮（排气）计数→成品输出全过程。
- 03 称量精度高、速度快，采用伺服驱动计量。
- 04 粉料密封输送、计量，不扬尘、不漏粉。搅拌功能，防止物料结块。
- 05 螺杆做工精致、计量准确，储料仓打开易清洗，性能稳定。
- 06 整套设备连续控制生产，自动控制供料，无料、缺料不包装，不浪费。

- ▶ FT-VP520L
- ▶ FT-VP730L
- ▶ FT-VP1200L



FT-VP420L

液体泵计量包装系列

LIQUID PUMP METERING PACKAGING SERIES

样袋展示 Sample bag display



牛奶

果酱



本套机组 This set of unit

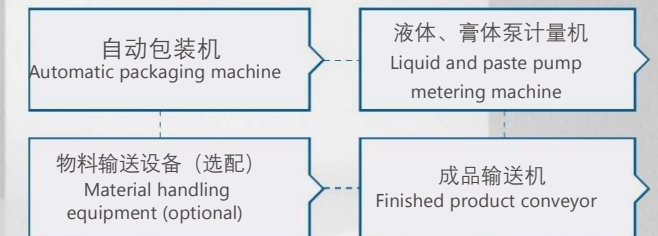

本设备技术优势 Technical advantages

- 01 适用于食品、化工产品、药品中的液体、膏体物料的自动包装，如：花生酱、果酱、面霜、沐浴露、洗发水、胶水、牛奶等。
- 02 称量精度高、速度快，采用伺服驱动计量，机械易操作、易维护。
- 03 整套设备连续控制生产，自动控制供料，无料、缺料不包装，不浪费。
- 04 液体泵与物料接触部分为 304 或 316 不锈钢，不易生锈。
- 05 密封输送、计量，干净卫生，不会对产品产生二次污染。

- 01 It is suitable for automatic packaging of liquid and paste materials in food, chemical products, medicines, such as: peanut butter, jam, facial cream, shower gel, shampoo, glue, milk, etc.
- 02 The weighing accuracy is high, the speed is fast, and the servo-driven metering is adopted, and the machine is easy to operate and maintain.
- 03 The whole set of equipment continuously controls production and automatically controls material supply. No material or lack of material will not be packaged or wasted.
- 04 The part of the liquid pump in contact with the material is 304 or 316 stainless steel, which is not easy to rust.
- 05 Sealed transportation, metering, clean and hygienic, no secondary pollution to the product.

FT-VP320/FT-KP320

全自动大型立式包装机

FULLY AUTOMATIC LARGE VERTICAL PACKAGING MACHINE



技术参数 Technical parameter

型号 Model	FT-VP320
速度范围 Speed range	5 ~ 90 包 / 分 Package/min
膜宽范围 Film wide range	80 ~ 320mm
制袋尺寸 Bag size	宽 width 50 ~ 150mm 长 long 30 ~ 200mm
薄膜厚度 Membrane thickness	0.03 ~ 0.09mm
外型尺寸 (长*宽*高) Dimensions (L*W*H)	1115*800*1370mm
耗气量 Air consumption	0.8Mps, 0.25m ³ /min
包装膜材料 Packaging film material	POPP/CPP, POPP/VMCPP, CPP/PE, Ect
卷膜内筒直径 Inner cylinder diameter of roll film	∅76mm
使用电源 Using electric	单相 Simplex 220V±5% 50 ~ 60HZ 2.2 ~ 3.9KW
报警状态 Alarm status	①无袋无料报警停机 ②设备过载报警 ③低温、无色带报警 ① No bag and no material alarm and shutdown ② Equipment overload alarm ③ Low temperature, no ribbon alarm

FT-VP520/FT-KP520

全自动大型立式包装机

FULLY AUTOMATIC LARGE VERTICAL PACKAGING MACHINE



技术参数 Technical parameter

型号 Model	FT-VP520
速度范围 Speed range	5 ~ 70 包 / 分 Package/min
膜宽范围 Film wide range	220 ~ 520mm
制袋尺寸 Bag size	宽 width 100 ~ 250mm 长 long 80 ~ 350mm
薄膜厚度 Membrane thickness	0.04 ~ 0.10mm
外型尺寸 (长*宽*高) Dimensions (L*W*H)	1560*1160*1530mm
耗气量 Air consumption	0.8Mps, 0.4m ³ /min
包装膜材料 Packaging film material	POPP/CPP, POPP/VMCPP, CPP/PE, Ect
卷膜内筒直径 Inner cylinder diameter of roll film	∅76mm
使用电源 Using electric	单相 Simplex 220V±5% 50 ~ 60HZ 2.2 ~ 3.9KW
报警状态 Alarm status	①无袋无料报警停机 ②设备过载报警 ③低温、无色带报警 ① No bag and no material alarm and shutdown ② Equipment overload alarm ③ Low temperature, no ribbon alarm

FT-VP420/FT-KP420

全自动大型立式包装机

FULLY AUTOMATIC LARGE VERTICAL PACKAGING MACHINE



技术参数 Technical parameter

型号 Model	FT-VP420
速度范围 Speed range	5 ~ 90 包 / 分 Package/min
膜宽范围 Film wide range	120 ~ 420mm
制袋尺寸 Bag size	宽 width 60 ~ 200mm 长 long 70 ~ 300mm
薄膜厚度 Membrane thickness	0.03 ~ 0.10mm
外型尺寸 (长*宽*高) Dimensions (L*W*H)	1530*970*1600mm
耗气量 Air consumption	0.8Mps, 0.5m ³ /min
包装膜材料 Packaging film material	POPP/CPP, POPP/VMCPP, CPP/PE, Ect
卷膜内筒直径 Inner cylinder diameter of roll film	∅76mm
使用电源 Using electric	单相 Simplex 220V±5% 50 ~ 60HZ 2.2 ~ 3.9KW
报警状态 Alarm status	①无袋无料报警停机 ②设备过载报警 ③低温、无色带报警 ① No bag and no material alarm and shutdown ② Equipment overload alarm ③ Low temperature, no ribbon alarm

FT-VP730/FT-KP730

全自动大型立式包装机

FULLY AUTOMATIC LARGE VERTICAL PACKAGING MACHINE



技术参数 Technical parameter

型号 Model	FT-VP730
速度范围 Speed range	5 ~ 50 包 / 分 Package/min
膜宽范围 Film wide range	300 ~ 720mm
制袋尺寸 Bag size	宽 width 140 ~ 350mm 长 long 200 ~ 400mm
薄膜厚度 Membrane thickness	0.04 ~ 0.12mm
外型尺寸 (长*宽*高) Dimensions (L*W*H)	1820*1430*2000mm
耗气量 Air consumption	0.8Mps, 0.35m ³ /min
包装膜材料 Packaging film material	POPP/CPP, POPP/VMCPP, CPP/PE, Ect
卷膜内筒直径 Inner cylinder diameter of roll film	∅76mm
使用电源 Using electric	单相 Simplex 220V±5% 50 ~ 60HZ 2.2 ~ 3.9KW
报警状态 Alarm status	①无袋无料报警停机 ②设备过载报警 ③低温、无色带报警 ① No bag and no material alarm and shutdown ② Equipment overload alarm ③ Low temperature, no ribbon alarm

FT-VP820/FT-KP820

全自动大型立式包装机

FULLY AUTOMATIC LARGE VERTICAL PACKAGING MACHINE

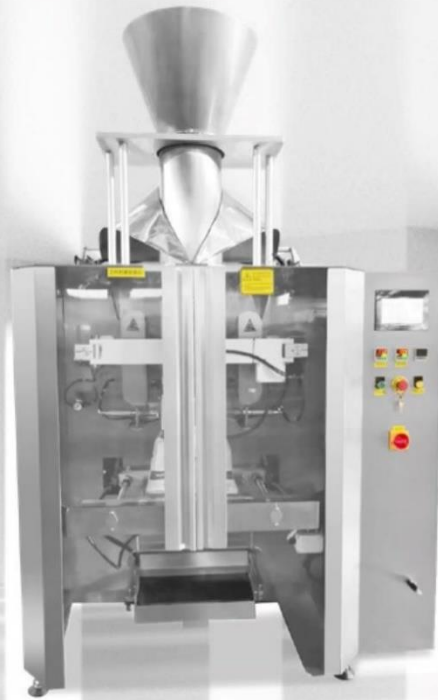

技术参数 Technical parameter

型号 Model	FT-VP820
速度范围 Speed range	5 ~ 50 包 / 分 Package/min
膜宽范围 Film wide range	300 ~ 820mm
制袋尺寸 Bag size	宽 width 250 ~ 400mm 长 long 200 ~ 500mm
薄膜厚度 Membrane thickness	0.04 ~ 0.12mm
外型尺寸 (长 * 宽 * 高) Dimensions (L*W*H)	1600*1530*2110mm
耗气量 Air consumption	0.65Mps, 0.8m ³ /min
包装膜材料 Packaging film material	POPP/CPP, POPP/VMCPP, CPP/ PE, Ect
卷膜内筒 直径 Inner cylinder diameter of roll film	∅ 76mm
使用电源 Using electric	单相 Simplex 220V±5% 50 ~ 60HZ 2.2 ~ 3.9KW
报警状态 Alarm status	①无袋无料报警停机 ②设备过载报警 ③低温、无色带报警 ① No bag and no material alarm and shutdown ② Equipment overload alarm ③ Low temperature, no ribbon alarm

样袋展示 Sample bag display



全自动化操作 Fully automated operation

所有型号的包装机均可与各种计量装置配套，可全自动完成送料→称量→充填→制袋→日期批号打印→充氮（排气）计数→成品输出全过程。

全自动称量系统

- 电脑组合秤（颗粒称量）。
- 螺杆计量机（粉末计量）。
- 液体泵（液体定量）。

全自动拉膜

- 伺服拉膜系统，代替人工纠偏，具备先进的自动纠偏功能。
- 运膜速度快，定位准确。
- 放膜杆加长，顺利拉膜，不容易报警和断膜。
- 拉膜加了压膜杆，方便接膜。

全自动制袋

- 定制 304 不锈钢制袋器，顺畅过膜，更好的成型成袋。
- 多个袋子尺寸，可更换多个制袋器共用一台机器使用，大大节省成本。
- 结构轻巧，更容易更换。

全自动封口

- 采用气动，动作平稳可靠，温度传导性好，升温快，封口牢固不漏气，制袋更美观。
- 纵封容易调整，不容易晃动。

All types of packaging machines can be matched with various measuring devices, which can automatically complete the whole process of feeding weighing → filling → bag making → date batch number printing → nitrogen filling (exhaust) counting → finished product output.

Fully automatic weighing system

- Computer combination weigher (particle weighing).
- Screw metering machine (powder metering).
- Liquid pump (liquid quantitative).

Fully automatic film drawing

- Servo film pulling system, instead of manual correction, has advanced automatic correction function.
- Fast film transport and accurate positioning.
- The film release rod is lengthened to pull the film smoothly, and it is not easy to alarm and break the film.
- Film pulling rod is added to facilitate film connection.

Automatic bag making

- Customized 304 stainless steel bag maker, smoothly pass the film, and better shape into a bag.
- With multiple bag sizes, multiple bag makers can be replaced and shared by one machine, which greatly saves costs.
- The structure is light and easy to replace.

Automatic sealing

- It adopts pneumatic, stable and reliable action, good temperature conductivity, fast heating, firm sealing and no air leakage, making the bag more beautiful.
- The longitudinal seal is easy to adjust and not easy to shake.

FT-VJ25

三角包装机

TRIANGLE PACKAGING MACHINE



技术参数 Technical parameter

名称 Name	内容 Content
最快包装速度 Fastest packaging speed	50 包 / 分 Package/min
制袋尺寸 Bag size	长 long 40-105mm 宽 width 30-85mm
制袋类型 Bag making type	三角袋 Triangle bag
最大膜宽 Maximum film width	250mm
薄膜厚度 Membrane thickness	0.04-0.09mm
包装膜材料 Packaging film material	BOPP/CPP,BOPP/VMCPP, BOPP/PE,PET/VMPET/PE,PET/PE,etc
耗气量 Air consumption	0.8Mps, 0.3m ³ /min
电源电压 Voltage	1.7KW, 220V, 50/60Hz
外型尺寸 (长 * 宽 * 高) Dimensions (L*W*H)	990*990*1085mm



FT-388

经济型立式包装机

ECONOMICAL VERTICAL PACKAGING MACHINE

技术参数 Technical parameter

名称 Name	内容 Content
最快包装速度 Fastest packaging speed	50 包 / 分 Package/min
制袋尺寸 Bag size	长 long 50-200mm 宽 width 50-150mm
制袋类型 Bag making type	背封袋 Back seal bag
最大膜宽 Maximum film width	320mm
薄膜厚度 Membrane thickness	0.04-0.07mm
计量范围 Measuring range	50-400ml
耗气量 Air consumption	0.8Mps, 0.25m ³ /min
电源电压 Voltage	2.2KW, 220V, 50/60Hz
外型尺寸 (长 * 宽 * 高) Dimensions (L*W*H)	595*620*1555mm



FT-VTQ420

立式袋四边烫倾斜包装机

VERTICAL BAG FOUR-SIDE IRONING AND TILTING PACKAGING MACHINE

- ▶ FT-VTQ520
- ▶ FT-VTQ620
- ▶ FT-VTQ820

样袋展示 Sample bag display



特别优势 Special advantage

- 01 专利倾斜结构设计，倾斜下料，保护容易摔碎的产品，比如膨化食品、冷冻饺子、饼干、水果等。
- 02 机型外观奢华高档，坚固的保护门拥有良好的防水和保护功能。
- 03 90%以上的零件采用304不锈钢材质，高品质，机器寿命更长。
- 04 电器元件采用大牌品牌，质量保证，机器运行更加平稳。
- 05 打码机倒置安装，更容易调节及更换。
- 06 全新升级改良后的成型器，使包装袋型更显高档美观。

- 01 Patented inclined structure design, inclined feeding, protect products that are easily broken, such as puffed food, frozen dumplings, biscuits, fruits, etc.
- 02 The appearance of the model is luxurious and high-end, and the sturdy protective door has good waterproof and protection functions.
- 03 More than 90% of the parts are made of 304 stainless steel, high quality and longer machine life.
- 04 The electrical components are of big brand, quality assurance, and the machine runs more smoothly.
- 05 The printer is installed upside down, making it easier to adjust and replace.
- 06 The newly upgraded and improved former makes the packaging bag more high-end and beautiful.

技术参数 Technical parameter

型号 Model	FT-VTQ420	FT-VTQ520	FT-VTQ620	FT-VTQ820
最快包装速度 Fastest packaging speed	5 ~ 60 包 / 分 Package/min	5 ~ 45 包 / 分 Package/min	5 ~ 40 包 / 分 Package/min	5 ~ 40 包 / 分 Package/min
膜宽范围 Film wide range	220 ~ 420mm	220 ~ 520mm	320 ~ 620mm	420 ~ 820mm
制袋尺寸 Bag size	正面宽 Front wide: 50-100mm 烫边宽 Hot edge width: 3-8mm 侧面宽 Wide side: 30-40mm 袋长 Bag length: 100-300mm	正面宽 Front wide: 70-120mm 烫边宽 Hot edge width: 3-8mm 侧面宽 Wide side: 30-100mm 袋长 Bag length: 200-400mm	正面宽 Front wide: 80-150mm 烫边宽 Hot edge width: 3-8mm 侧面宽 Wide side: 40-100mm 袋长 Bag length: 200-400mm	正面宽 Front wide: 100-180mm 烫边宽 Hot edge width: 3-8mm 侧面宽 Wide side: 50-120mm 袋长 Bag length: 200-400mm
薄膜厚度 Membrane thickness	0.04 ~ 0.12mm			
电源电压 Voltage	4.5KW,220V,50HZ	5KW,220V,50HZ	5.5KW,220V,50HZ	6KW,220V,50HZ
可选配置 Optional	插脚装置、打孔装置、“PE”膜装置、除尘装置、自动纠偏装置、连袋装置、真空拉膜、充气装置			

FT-VF360

平面四边封立式包装机

FLAT FOUR-SIDE SEALING VERTICAL PACKAGING MACHINE

- ▶ FT-VF520
- ▶ FT-VF820

样袋展示 Sample bag display

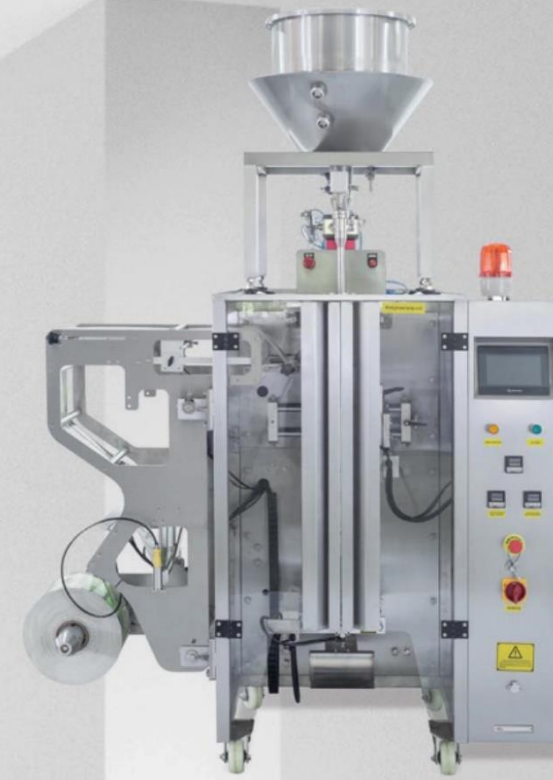

特别优势 Special advantage

- 01 横封结构配置新型防折装置，调整方便，性能稳定。
- 02 真空拉膜，配置行星减速器的伺服拉膜系统，运行更加精准，更加稳定。
- 03 自动纠偏系统，跟踪对位准确方便，适应了不同客户需求，开拓更为广阔的市场。
- 04 改良后的成型器，结构设计轻巧，更方便安装，还运用了杠杆锁紧器，安装紧固，不会自动松动。

- 01 The horizontal sealing structure is equipped with a new type of anti-folding device, which is convenient to adjust and stable in performance.
- 02 Vacuum film drawing, servo film drawing system equipped with planetary reducer, the operation is more precise and stable.
- 03 Automatic correction system, accurate and convenient tracking and alignment, adapted to different customer needs, and opened up a broader market.
- 04 The improved shaper has a lighter structure design and is more convenient to install, A lever locker is also used, which is tightly installed and will not loosen automatically.

技术参数 Technical parameter

型号 Model	FT-VF360	FT-VF520	FT-VF820
最快包装速度 Fastest packaging speed	40 包 / 分 Package/min	40 包 / 分 Package/min	40 包 / 分 Package/min
用膜范围 Film range	120-360mm	190-520mm	300-820mm
制袋尺寸 Bag size	长 long: 50-260mm 宽 width: 60-180mm	长 long: 50-350mm 宽 width: 90-260mm	长 long: 150-510mm 宽 width: 150-410mm
制袋类型 Bag making type	四边封、三边封 Four-side seal, three-side seal	四边封、三边封 Four-side seal, three-side seal	四边封、打孔挂袋 Four-side sealing, perforated hanging bag
薄膜厚度 Membrane thickness	0.04-0.09mm	0.04-0.09mm	0.04-0.09mm
外型尺寸(长*宽*高) Dimensions (L*W*H)	1140*1460*1470mm	1400*1260*1680mm	2120*1580*2000mm
电源电压 Voltage	6.0KW, 220V, 50/60HZ	4.0KW, 220V, 50/60HZ	6.0KW, 220V, 50/60HZ
耗气量 Air consumption	0.8Mps, 0.5m ³ /min	0.8Mps, 0.35m ³ /min	0.8Mps, 0.5m ³ /min

多列包装机

MULTI-COLUMN PACKAGING MACHINE

样袋展示 Sample bag display



特别优势 Special advantage

- 01 进口 PLC 控制系统，具有产量计算器和自我诊断功能。
- 02 先进的设计，达到高精度，高速度，高效率。
- 03 整机 90% 以上的零件采用 304 不锈钢材质，90% 以上的电器元件采用先进品牌，真正的高品质，保证了机器的稳定运行，使用寿命更长。
- 04 可旋转触摸屏，可调节高低，更体现机器人人性化的构造。
- 05 热封拉袋系统配合光电袋长跟踪，确保拉袋快速平稳。
- 06 采用灵活地模块设计，可按客户要求定制。

技术参数 Technical parameter

型号 model	FT- VL60	FT- VL80
最快包装速度 Fastest packaging speed	20-30 包 / 分 Package/min	20-30 包 / 分 Package/min
用膜范围 Film range	200-600mm	400mm-800mm
制袋尺寸 Bag size	长 long : L50-200mm 宽 width: 15-35mm	长 long: 60-200mm 宽 width: 15-35mm
制袋类型 Bag making type	背封、打孔挂袋、连带 Three-side sealing, perforated hanging bag, joint belt	背封、打孔挂袋、连带 Three-side sealing, perforated hanging bag, joint belt
薄膜厚度 Membrane thickness	0.04-0.09mm	0.04-0.09mm
外型尺寸 (长 * 宽 * 高) Dimensions (L*W*H)	1500*1420*1710mm	2200*1460*1800mm
电源电压 Voltage	5.5KW, 220V, 50/60HZ	6.2KW, 220V, 50/60HZ
耗气量 Air consumption	0.8Mps, 0.7m ³ /min	0.8Mps, 0.7m ³ /min

▶ FT-8G200/250

▶ FT-8G300

八工位给袋机
Eight-station bag feeding machine②八工位给袋机配螺杆配套系统
② eight-station bag machine is equipped with screw supporting system

产品介绍 Special advantage

全自动给袋式包装机是针对外观要求较高的预制袋进行包装的自动化设备，通过多工位来完成对包装袋的取袋、打码、开袋、填充振实、捅料、封口、整形输出成品，适用于各种颗粒、酱液、粉剂物料，被广泛应用于食品、医药、饮料、化工、农业、五金、玩具等行业。

特征及性能 Special advantage

- 01 设有多种自动诊断自动报警安全保护功能，最大限度保证人身安全，减少物料损耗。
- 02 可配备远程诊断系统，最短时间为机器排除故障。
- 03 可配备自动润滑系统，延长机器寿命，降低劳动成本。
- 04 可配备一键调夹系统，根据包装袋宽度快速调整机器。

八工位给袋式全自动包装机

EIGHT-STATION BAG-FEEDING AUTOMATIC PACKAGING MACHINE

①八工位给袋机配组合秤配套系统
① Eight station bag machine with combination weigher supporting system③八工位给袋机配液体泵配套系统
③ Eight station bag machine with liquid pump supporting system

The automatic bag-feeding packaging machine is an automatic equipment for packaging prefabricated bags with high appearance requirements. It uses multiple stations to complete the bag taking, coding, bag opening, filling and tapping, poke, sealing, Shaping and exporting finished products are suitable for all kinds of particles, sauces, powder materials, and are widely used in food, medicine, beverage, chemical, agriculture, hardware, toys and other industries.

- 01 Equipped with a variety of automatic diagnosis and automatic alarm safety protection functions to maximize personal safety and reduce material loss.
- 02 It can be equipped with a remote diagnosis system, which can troubleshoot the machine in the shortest time.
- 03 It can be equipped with an automatic lubrication system to extend the life of the machine and reduce labor costs.
- 04 It can be equipped with a one-button adjustment system to quickly adjust the machine according to the width of the packaging bag.



④八工位给袋机配碗式提升机
④ Eight station bag machine with bowl elevator



上取袋单工位给袋机
Single-station bag feeding machine

样袋展示 Sample bag display



下取袋单工位给袋机
Lower bag single station bag feeding machine

可选配套设备 Special advantage

开拉链装置
Zipper opening device

合拉装置
Pull device

捅料装置
Poke device

充气装置
Inflatable device

排气装置
Exhaust

清扫袋口装置
Device for cleaning bag opening

下振料装置
Lower vibrating device

技术参数 Technical parameter

型号 model	FT-8G200	FT-8G250	FT-8G300
最快包装速度 Fastest packaging speed	60包/分 Package/min (具体根据包装膜质量, 包装物料包装重量而定) (It depends on the quality of packaging film and the weight of packaging materials)		
制袋尺寸 Bag size	长 long: 100-300mm 宽 width: 70-200mm	长 long: 100-350mm 宽 width: 130-250mm	长 long: 150-450mm 宽 width: 200-300mm
制袋类型 Bag making type	预制袋、自立袋、四边封袋、三边封袋、异形袋 Prefabricated bags, self-supporting bags, four-side sealing bags, three-side sealing bags, special-shaped bags		
称量范围 Weighing range	10g-1kg	10g-2kg	10g-3kg
计量精度 Measurement accuracy	≤ ±0.5-1.0% 具体视计量设备及物料确定 It depends on the measurement equipment and materials		
最大包装袋宽 Maximum bag width	200mm	250mm	300mm
外型尺寸(长*宽*高) Dimensions (L*W*H)	1900*1400*1450mm	1900*1400*1450mm	2000*1500*1550mm
耗气量 Air consumption	0.8Mps, 0.3m³/min		
总功率 Total power	1.5KW, 380V, 50/60HZ	1.8KW, 380V, 50/60HZ	2KW, 380V, 50/60HZ

14头微型组合秤

14 HEAD MINI COMBINATION WEIGHER



0.5L 料斗
0.5L Hopper

10头微型组合秤

10 HEAD MINI COMBINATION WEIGHER



5L 料斗
5L Hopper

14头沙拉组合秤

14-HEAD SALAD COMBINATION WEIGHER



1.6-2.5L
1.6-2.5L

20头标准组合秤

20 HEAD STANDARD COMBINATION WEIGHER



32斗混料型组合秤

32 BUCKET MIXING TYPE COMBINATION WEIGHER



细节特写 Detail close-up



4 头线性秤
4-HEAD LINEAR SCALE

主要优势 Special advantage

- 01 料斗容量 0.5L~10L, 可称 30~2000g, 称重速度 10~70 包 / 分, 可称物料 4 种。
 - 02 带有气动开门装置, 可实现自动关闭加料振机。
 - 03 与物料接触部件 (储料斗、下料斗、振盘、称量斗等) 均实现快速拆卸, 清尤为方便。
- 01 The hopper capacity is 0.5L~10L, can weigh 30~2000g, weighing speed is 10~70 bags/min, and 4 kinds of materials can be weighed.
 - 02 With a pneumatic door opening device, it can automatically close the feeding vibration machine.
 - 03 The parts in contact with the material (storage hopper, lower hopper, vibrating plate, weighing hopper, etc.) can be quickly disassembled, which is particularly convenient for cleaning.

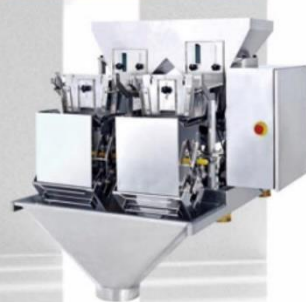
2 头线性秤
2-HEAD LINEAR SCALE

主要优势 Special advantage

- 01 适合白糖、种子、大米、咖啡、调味粉等粉状、小颗粒状较为均匀物料的定量称量。
 - 02 料斗容量 3L~50L, 可称 500~5000g, 最高速度 5~25 包 / 分, 可称物料 2 种。
 - 03 全部采用不锈钢材料制作, 干净卫生。
- 01 It is suitable for quantitative weighing of powdery and small granular materials such as sugar, seeds, rice, coffee, seasoning powder and other relatively uniform materials.
 - 02 The hopper capacity is 3L~50L, can weigh 500~5000g, the maximum speed is 5~25 bags/min, and can weigh 2 kinds of materials.
 - 03 All made of stainless steel, clean and hygienic.

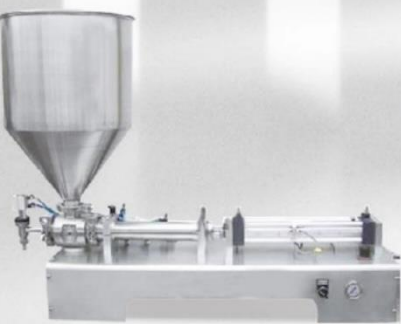
液体计量泵
LIQUID METERING PUMP

主要优势 Special advantage

- 01 电器元件均采用名牌产品, 性能稳定可靠。
 - 02 有小、中、大三个型号可供客户选择, 满足不同需求。
 - 03 液体泵采用高品质 304# (可定制 316#) 不锈钢材质。
- 01 The electrical components are all famous-brand products with stable and reliable performance.
 - 02 There are three models of small, medium and large for customers to choose to meet different needs.
 - 03 The liquid pump is made of high-quality 304# (316# can be customized) stainless steel.

螺旋计量机
SCREW WEIGHING MACHINE

主要优势 Special advantage

- 01 整机全不锈钢制作, 符合 GMP 食品 卫生认证。
 - 02 采用伺服电机驱动计量, 具有精度高、速度快、性能稳定、寿命长等优点。
 - 03 全密封玻璃不锈钢复合料箱, 物料情况一目了然。
- 01 The whole machine is made of stainless steel and complies with GMP food hygiene certification.
 - 02 It adopts servo motor to drive the metering, which has the advantages of high precision, fast speed, stable performance and long life.
 - 03 Fully sealed glass stainless steel composite material box, the material situation is clear at a glance.

计量装置
METERING DEVICE

主要优势 Special advantage

- 01 采用高品质不锈钢材质, 不生锈, 安全卫生。
 - 02 计量重量范围, 精度高、速度快。
 - 03 调节简单, 清洗维护方便。
- 01 Made of high-quality stainless steel, no rust, safe and hygienic.
 - 02 Wide range of measuring weight, high precision and high speed.
 - 03 Easy to adjust, easy to clean and maintain.

重量选别秤
WEIGHT SELECTION SCALE

主要优势 Special advantage

- 01 在包装物料时出现少装、多装、漏装、缺重、超重等可在线自动检测, 并自动剔除不良物料、分选物料, 精确度达到 ≥ 0.05 克。
 - 02 液晶显示触摸屏操作系统, 中英文操作界面, 方便易学。
 - 03 自我诊断功能, 当光电管通讯异常时, 会有出错显示。
- 01 When packing materials, it can be automatically detected online, such as under-packing, over-packing, missing packing, lack of weight, overweight, etc., and automatically remove bad materials and sort materials, with an accuracy of ≥ 0.05 grams.
 - 02 LCD touch screen operating system, Chinese and English operation interface, convenient and easy to learn.
 - 03 Self-diagnosis function, when the photocell communication is abnormal, there will be an error display.

金属检测器
METAL DETECTOR

主要优势 Special advantage

- 01 可探测物料包装过程混入的铜、铝、铁、非铁、不锈钢等所有金属异物。
 - 02 高精度探头, 可检测高达 0.5mm 的金属。
 - 03 具有超高灵敏度、强抗干扰能力以及超强的防震能力。
 - 04 检测到金属自动报警, 精准不误漏。
- 01 It can detect all metal foreign objects such as copper, aluminum, iron, non-ferrous, stainless steel, etc. mixed in the material packaging process.
 - 02 High-precision probe that can detect metals up to 0.5mm.
 - 03 It has ultra-high sensitivity, strong anti-interference ability and strong shock-proof ability.
 - 04 Automatic alarm when metal is detected, accurate and accurate.

Z 型物料输送机
Z TYPE MATERIAL CONVEYOR

主要优势 Special advantage

- 01 用于垂直输送流动性好的颗粒及小块状的物料, 具有提升量大, 提升度高等优点。
 - 02 所有齿轮加粗, 噪声小。链条加粗, 运转更平稳。
 - 03 输送料斗为扣半式, 不会掉料及掉斗。
 - 04 不锈钢材质制作, 全封闭式, 干净卫生。
- 01 It is used for vertical conveying of granules and small block materials with good fluidity, and has the advantages of large lifting capacity and high lifting degree.
 - 02 All gears are bold and the noise is small. The chain is thicker and runs more smoothly.
 - 03 The conveying hopper is a half-buckle type, which will not drop the material and the hopper.
 - 04 Made of stainless steel, fully enclosed, clean and hygienic.

斜坡输送机
RAMP CONVEYOR



技术参数 Technical parameter

名称 Name	内容 Content
功率 Power	0.55~1.1KW
输送量 Conveying capacity	2~6m ³ /h
电压 Voltage	220V/380V
毛重 Gross weight	500KG

主要优势 Special advantage

- 01 该提升机与电子计量秤配套使用，并用控制电路以料位控制，实现自动供料和停止的自动化功能。
- 02 该提升机有不锈钢和碳钢两种材料制作，供用户选择。可按用户要求定制不同规格。
- 01 The elevator and electronic metering scale shall be used together, control circuit is used to control the position of the material, realizing automatic feeding and stopping function.
- 02 The elevator can be made of stainless steel and carbon steel according to the customer choice.

水平快退式输送机
HORIZONTAL FAST RETREAT CONVEYOR



主要优势 Special advantage

- 01 适用于各种包装物料的输送。
- 02 输送重量优于其他输送机，达到 27 吨 / 时。
- 03 柔和送料，不粘料，不碎料。
- 04 清洗维护方便。
- 01 It is suitable for conveying various packaging materials.
- 02 The conveying weight is better than other conveyors, reaching 27 tons/hour.
- 03 Soft feeding, no sticking, no scraping.
- 04 Easy to clean and maintain.

真空上料机
VACUUM FEEDER



主要优势 Special advantage

- 01 操作简单，无泄漏现象。
- 02 上料速度快，连续工作时间长。
- 03 拆装和清洗方便，干净卫生，复合卫生要求。
- 01 Simple operation and no leakage.
- 02 The feeding speed is fast and the continuous working time is long.
- 03 It is easy to disassemble and clean, clean and hygienic, and meets the hygienic requirements.

成品输送机 & 成品转盘
FINISHED PRODUCT CONVEYOR & FINISHED PRODUCT TURNTABLE



主要优势 Special advantage

- 01 适用于将包装好的成品袋输送至包装后的检测设备或打包平台。
- 02 成品转盘采用 304 不锈钢，具备 360 度旋转功能。
- 03 设备高度可调节，皮带和链板材质可供客户选择。
- 04 成品输送机有不锈钢和喷漆两种材质可供选择。
- 01 It is suitable for transporting the packaged finished bags to the testing equipment or packaging platform after packaging.
- 02 The finished turntable is made of 304 stainless steel and has a 360-degree rotation function.
- 03 The height of the equipment is adjustable, and the material of belt and chain plate can be selected by customers.
- 04 Finished conveyors are available in stainless steel and painted.

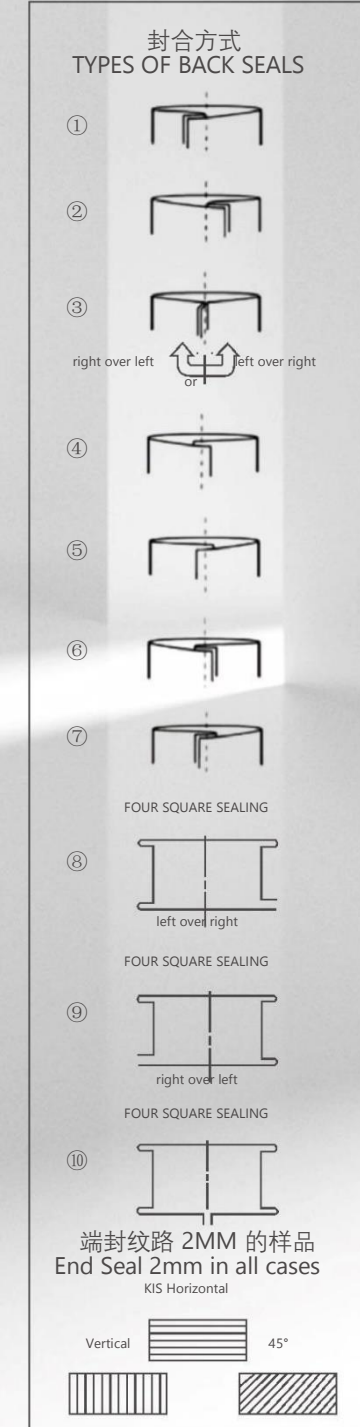
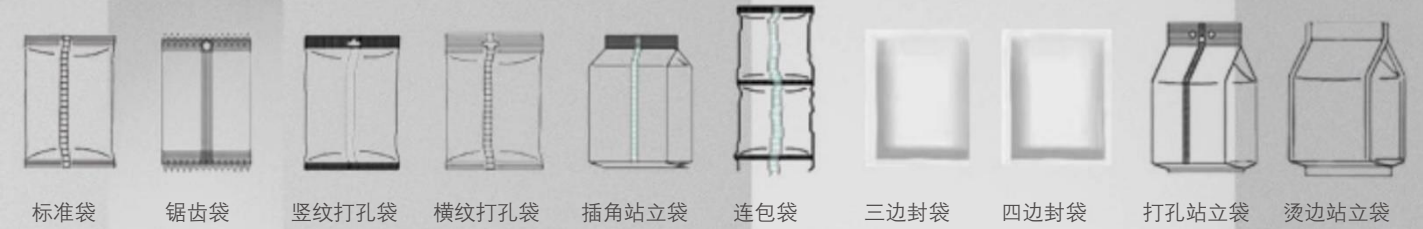

机型编号说明
Description of the model number

FT	V	P	420	A
----	---	---	-----	---

公司名称：峰拓机械
Company: FRONTECH MACHINERY

横封运动方式：V-普通气动 K-伺服快速
G-连续式高速 R-往复式

The transverse sealing mode of motion: V-General aerodynamics
G-Continuous high speed
K-High-speed servo
R-Reciprocating

机器形状：P-立式，Q-倾斜式，T-烫边机
Y-一体机，J-三角机，F-四边封

Type of the machine: P-Vertical
Q-Inclined
T-Ironing machine of edge.
Y-The body of the machine
F-Four-edge sealing
J-Triangle machine

机型最大包装膜规格：420-最大包装膜 420mm

The biggest size of the packaging films for the model:
420-The biggest size of the packaging films 420mm

计量方式：A-组合称计量
B-容积计量 C-电子称称量
D-螺杆计量 L-液体膏体泵计量

Measurement methods: A-Measuring of the combined weigher
B-Volume measurement
C-Weighing of electronic scale
D-Screw metering L- Metering pump of liquid and paste
L-liquid paste pump metering